

W

HIGH PRESSURE-FLOW PLUNGER

S E R I E S O F M E T E R I N G P U M P S

We Are Committed to Delivering Fluid Metering Products, Services & Technology of the Highest Quality, and To Always Exceed Our Customer's Expectations.



"Pneumatic Operation"

- *Intrinsically Safe*
- *Easy To Install*
- *Simple To Maintain*

*Flow Rates From 9 to 90 GPH
With Discharge Pressures
To 3450 PSIG*



WILLIAMS
INSTRUMENT INCORPORATED

MILTON ROY

A Sundstrand Company

**MEETS API 675
REQUIREMENTS**

WHI PRESSURE FLOW PLUNGER

SERIES OF METERING PUMPS

SIMPLICITY IN DESIGN, OPERATION AND MAINTENANCE

FEATURES:

- Simple Design
- Easy to Maintain
- Intrinsic Safety of Pneumatic Operation
- Stroke Length and Stroke Rate Adjustment
- High Flow Turndown
- Corrosion Resistant Construction
- All 316 SS Wetted Parts
- Ease of Installation

STANDARD MATERIALS:

- Wetted Parts: 316 SS
- Plunger: 316 SS, 17-4 SS or Ceramic
- Controller - MK XII: 316 SS
- Relays - P04-6S or P04-8S: 316 SS

SEAL MATERIALS:

- Teflon® Graphite (TG) for pressures of 1000 to 10,000 PSIG
- O-Ring seals are available for pressures below 900 PSIG in various materials, K-Kalrez®, V-Viton® and BR-Buna N, EPR-Ethylene Propylene.

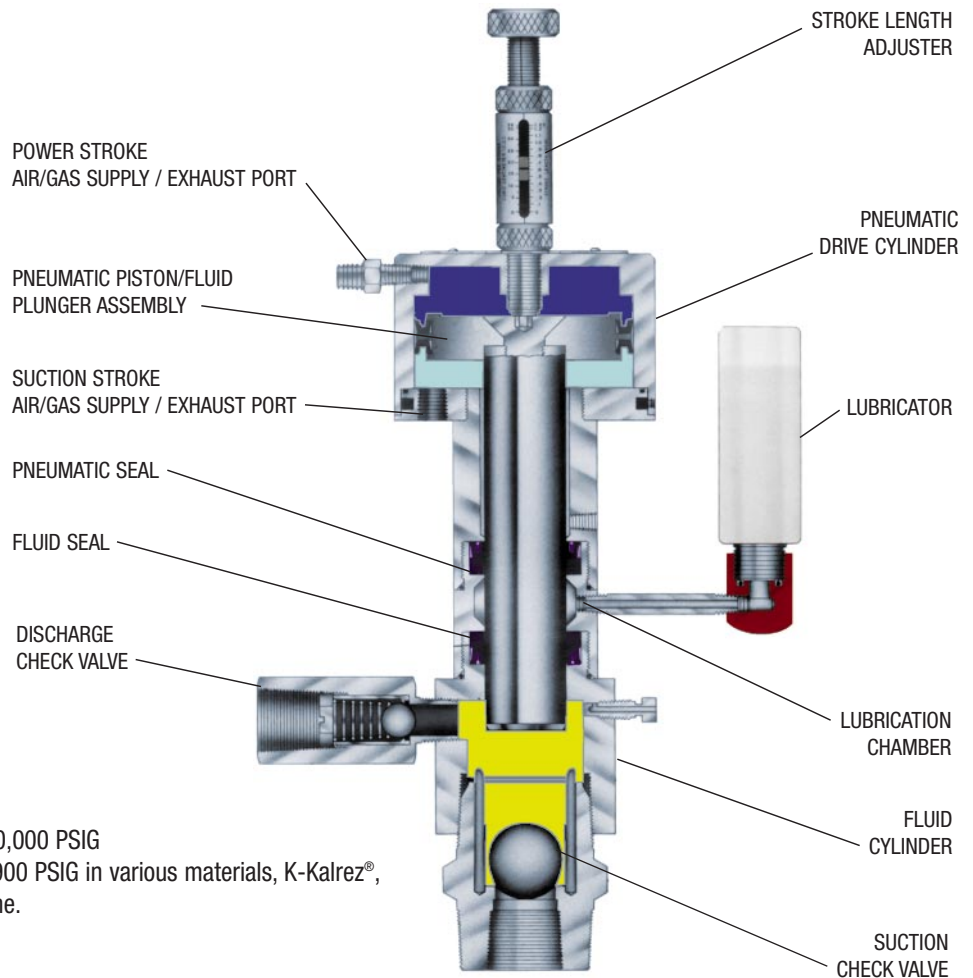

OPERATING CYCLE

POWER STROKE: As the supply air/gas from the CONTROLLER-RELAY enters the PNEUMATIC DRIVE CYLINDER thru the POWER STROKE PORT, the PISTON-PLUNGER ASSEMBLY is driven down into the FLUID CYLINDER, displacing fluid. The fluid displacement results in an increase in pressure which closes the SUCTION CHECK VALVE and opens the DISCHARGE CHECK VALVE. A precise amount of fluid, corresponding to the stroke of the plunger, is discharged.

SUCTION STROKE: When the air/gas is exhausted from the top portion of the PNEUMATIC DRIVE CYLINDER through the CONTROLLER-RELAY, air/gas is then supplied to the bottom portion of the PNEUMATIC DRIVE CYLINDER in order to return the PISTON-PLUNGER to its original position. The drop in pressure caused by the retraction of the PISTON-PLUNGER assembly allows the DISCHARGE CHECK VALVE to close, and the SUCTION CHECK VALVE to open. The FLUID CHAMBER is then refilled and ready for the POWER STROKE.

PERFORMANCE SPECIFICATIONS

Models	Plunger Diameter (Inch)	Piston Diameter (Inch)	Maximum Volume		Maximum Pressure ⁽²⁾		Amp. Ratio	Strokes per Minute (SPM)	Volume per Stroke (cc)	Stroke Length (Inch)	Max. Air Usage At Max. Volume				Approx. Shipping Weight	
											100 PSI	6.9 Bar	150 PSI	10.3 Bar		
			Gal./Hr.	Liter/Hr.	PSI	Bar					SCF/D	SCM/D	SCF/D	SCM/D	Lbs.	Kg.
CRP1500W400	1 1/2	4	22.90	86.40	600	41	4:1	1-40	36.0	1 1/4	8,604	228	11,543	326	33	15.0
CRP1500W600	1 1/2	6	22.90	86.40	1,950	134	13:1	1-40	36.0	1 1/4	18,144	1,251	26,000	736	39	17.7
CRP1500W800	1 1/2	8	22.90	86.40	3,450	238	23:1	1-40	36.0	1 1/4	32,256	913	46,000	1,302	44	20.0
CRP2250W600L	2 1/4	6	90.00	336.00	900	62	6:1	1-35	160.0	2 1/2	32,000	906	46,000	1,302	59	26.8
CRP2250W800L	2 1/4	8	90.00	336.00	1,800	124	12:1	1-35	160.0	2 1/2	57,000	1,614	81,000	2,293	84	38.2

NOTE: ⁽¹⁾ The minimum volume recommended for any pump should be calculated on the basis of 1/4 inch minimum stroke length and 5 strokes per minute minimum speed with controller, or 1 stroke per minute with solenoid.

⁽²⁾ The maximum discharge pressure is achieved using 150 PSI (10.3 BAR) air/gas supply pressure.

PLUNGER PUMP SELECTION GUIDELINES

STROKE RATE AND LENGTH

Even though the pumps are designed to operate over their entire stroke rate and length ranges, we suggest that you take into consideration your future flow requirements. Rather than operating at the flow extremes you may wish to use the next pump size larger or smaller.

FILTRATION

Plunger pumps are susceptible to contamination. Therefore, we recommend a **25 micron** filter in the suction line of the pump.

SUCTION CONDITIONS

The W Series plunger pumps are designed for flooded suction only. They are NOT recommended for a suction lift condition. The recommended pressure at the suction inlet is:

1 ft. (.3 meters) min. • 10 ft. (3 meters) max.

NOTE: The normal cracking pressure of the discharge check valve is 90 PSI.

ACCURACY

± 0.5% with Solenoid Valve and WPC-9001
± 1.5% with MK XII Controller

VISCOSITY

The maximum recommended viscosity is 4500 SSU (Saybolt Seconds Universal) or 960 CP (Centipoise).

FLOW TURNDOWN RATIO: 100:1

NOTE: The flow turndown ratio is defined as the total flow range of the pump, which includes both speed and stroke length adjustments.

TEMPERATURE

The seal material is the limiting factor:

TG (Teflon® Graphite):	-30° to 180°F (-34° to 82°C)
Viton®:	-10° to 200°F (-23° to 93°C)
Buna N:	-40° to 200°F (-40° to 93°C)
Kalrez®:	32° to 200°F (0° to 93°C)
EPR (Ethylene Propylene):	-40° to 200°F (-40° to 93°C)

AIR/GAS SUPPLY

The air/gas supply must always be regulated since fluctuating pressures will affect speed and accuracy. The air/gas must be free from particulate and we recommend dry air/gas for trouble free operation. Since the controller and relay operate at different pressures they must have separate regulated supplies.

PUMP SETTING GAUGE

We recommend the use of a pump setting gauge as a simple method of adjusting the flow of the pump.

DISCHARGE LINE CHECK VALVE

It is good design practice to install a check valve in the pump discharge line at the point it enters the process line. This will prevent the process fluid from reaching the pump.

AMPLIFICATION RATIO

The amplification ratio is the area difference between the air piston and the fluid plunger.

To ensure a longer operational life of the pump, it is important not to use a greater air supply pressure than is necessary to provide positive chemical injection. Assuming a specific amplification ratio, the air supply pressure must be regulated to ensure that the pump discharge pressure is greater than the process pressure. In calculating the proper air supply pressure, add 200 PSI (13.8 BAR) to the process pressure, then divide by the amplification ratio.

EXAMPLE:

- Assume a process pressure of 2800 PSI (193 BAR) (process pressure is the pressure into which the chemical is injected).
- Add 200 PSI to the process pressure so that the chemical is positively injected:
2800 PSI + 200 PSI = 3000 PSI (193 BAR + 13.8 BAR = 206.8 BAR).
- Assume using a Williams pump with an amplification ratio of 23:1 (implies that for every 1 PSI (1 BAR) input pressure, the pump produces 23 PSI (23 BAR) output pressure).
- Supply of air or gas pressure to controller is:
3000 ÷ 23 = 130 PSI (206.8 BAR ÷ 23 = 9 BAR).

CONTROL METHODS FOR THE PUMP

MK XII OSCILLAMATIC® CONTROLLER

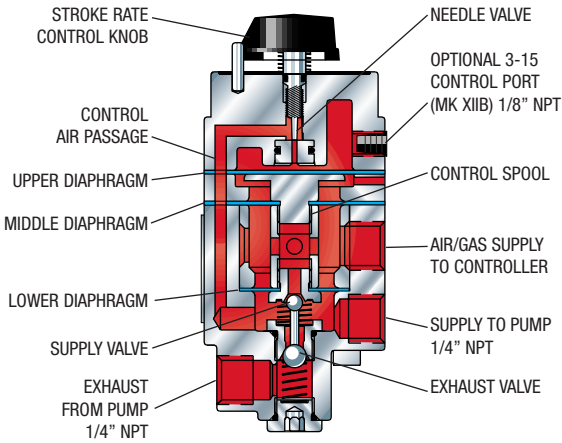

The MK XIIA Controller operates on the same operating principal as the MK X Controller. The MK XIIA has the same upper and lower chambers, but are separated with flexible diaphragms rather than sliding seals. A capillary tube, controlled by a needle valve, transfers the air/gas supply to the pump from the lower to the upper chamber.

When the spool is in the highest position, a pilot plug closes a vent and opens the supply air/gas to the pump. When the spool is in its lowest position, the pilot plug prevents the supply air/gas from entering the pump, and opens the air/gas vent to let it exhaust the pump. The spool then returns to its highest position to repeat the process.

CONTROLLER-PNEUMATIC RELAY COMBINATION

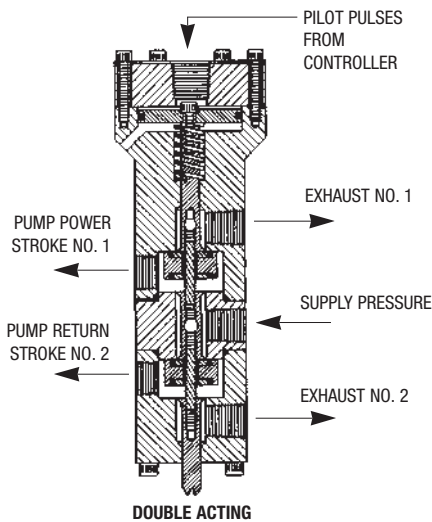

All models of the P1500W and P2250W use the PNEUMATIC RELAY in combination with the MK XII CONTROLLER. The PNEUMATIC RELAY is a pilot operated valve designed to provide the higher air or gas flows rates necessary to operate the larger diameter PNEUMATIC DRIVE CYLINDERS. The PNEUMATIC RELAY is actuated by the pulses produced by the MK XII Oscillamatic® controller. In the P1500W and P2250W pumps the supply air is used on both the POWER and SUCTION strokes. The PNEUMATIC RELAY is double acting. It alternately supplies and exhausts the air/gas to the top and bottom of the piston driving it up and down.

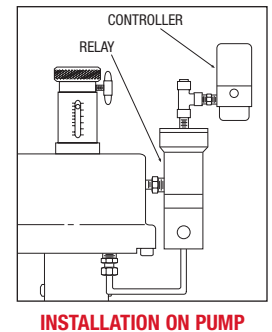

INSTALLATION ON PUMP

SOLENOID VALVES

The pumps can be automated by replacing the CONTROLLER with a 3-way electro-pneumatic SOLENOID VALVE. The SOLENOID VALVE can be cycled in order to achieve the desired pump output. Flow tracking can be accomplished by having a FLOWMETER or PH METER signal interpreted by our WPC9001 or a PLC. The typical arrangement for a WPC-9001 installation is shown at right.

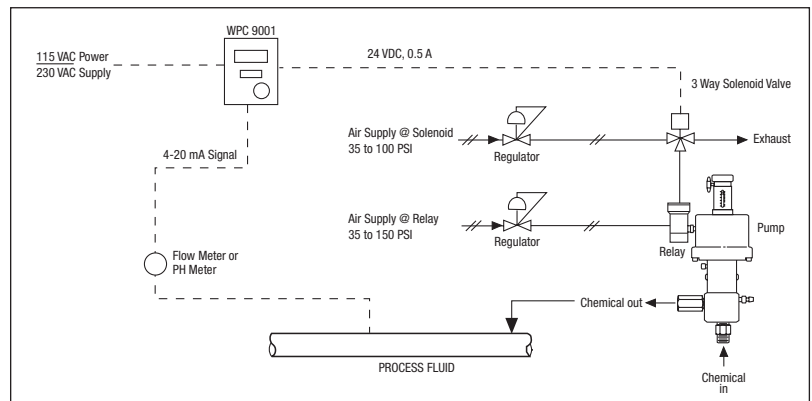

PERFORMANCE

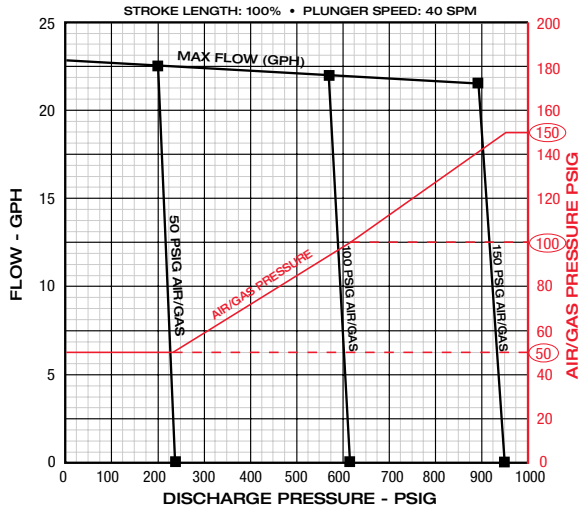

CRP1500W400

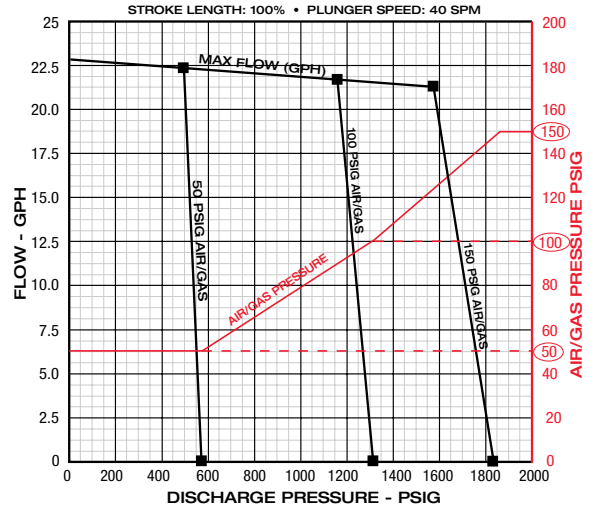

CRP1500W600

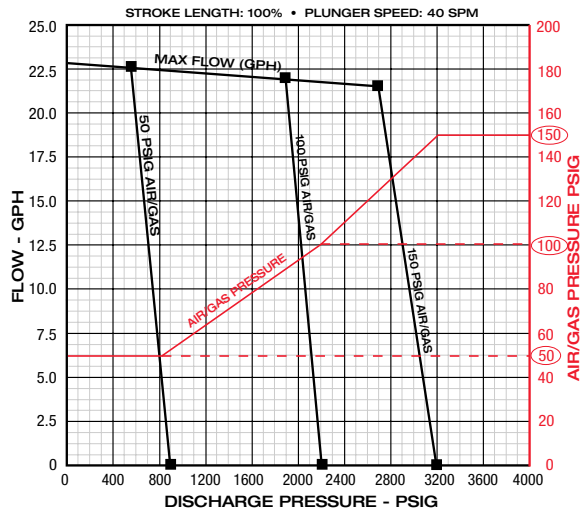

CRP1500W800

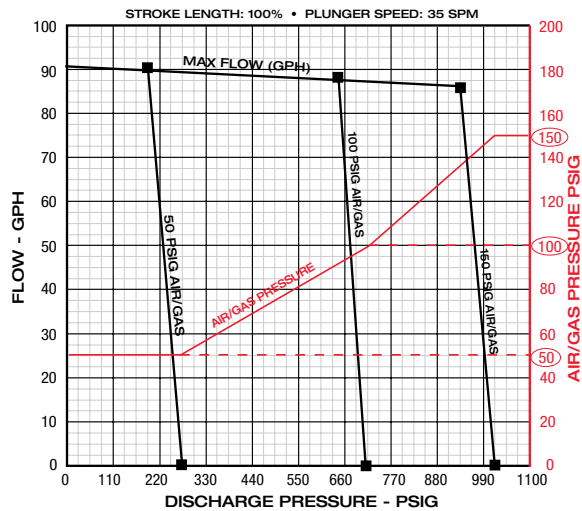

CRP2250W600

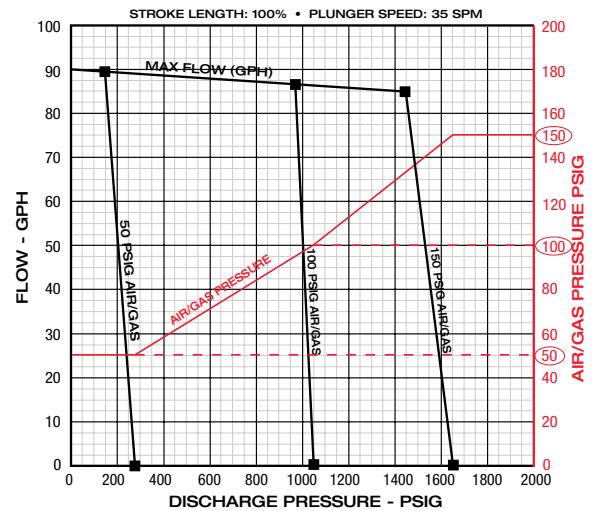

CRP2250W800

PLUNGER MATERIAL SELECTION

The materials available vary in hardness and chemical compatibility. We offer three materials based on our many years of industry experience with various chemicals. Hardness is a key property when selecting the proper plunger material. Our experience has shown that the harder plunger materials not only provide longer plunger life, they also provide greater seal life. A hard plunger is a must when pumping a chemical that is prone to crystallization or if the chemical is contaminated. Of course both of the above conditions will affect seal life. Below is a table that compares the chemical compatibility and hardness properties of each material.

DESIGNATION	MATERIAL	HARDNESS	CHEMICAL COMPATIBILITY
CR	Ceramic	Between Sapphire and Diamond on the Mohs' Scale	Excellent Chemical Inertness in all Acids, Bases, Solvents
A	17-4 ph	40 Rc	General Corrosion-resistant Stainless Steel Limited Acid Resistance
B	316 SS	28 Rc	Excellent Corrosion-resistant Stainless Steel Limited Acid Resistance

We recommend the use of ceramic because of its extreme hardness and excellent chemical inertness.

SEAL MATERIAL SELECTION

The seal material must be chosen to satisfy both the chemical compatibility and the pressures/temperatures at which you are operating. Below is a general guideline for seal material selection.

MATERIAL	SEAL TYPE	TEMP RANGE	SUGGESTED PRESSURE RANGE	COMMENTS
TG Teflon® Graphite	Mechanical (Spring Loaded)	-30 to 180°F -34 to 82°C	1000 to 10,000 psi 70 to 690 bar	Tough material with excellent wear resistance. Excellent chemical inertness. Good for all types of chemicals, acids, bases or solvents. Recommended for use with the harder ceramic plunger and higher pressures.
V Viton®	O-ring	-10 to 200°F -23 to 93°C	100 to 750 psi 6.9 to 52 bar	Soft material with fair wear resistance. Broad chemical compatibility but its not to be used with ethyl or methyl alcohols. Suggested only for hard to seal fluids in low pressure applications when PE or TC will not seal.
BR Buna N	O-ring	-40 to 200°F -40 to 93°C	100 to 750 psi 6.9 to 52 bar	Soft material with fair wear resistance. Limited chemical compatibility. Used mainly in Methanol pumping at low pressure.
K Kalrez®	O-ring	32 to 200°F 0 to 93°C	100 to 750 psi 6.9 to 52 bar	Soft material with fair wear resistance. Excellent chemical compatibility. Used when Viton® is not compatible and PE or TC will not seal.
EPR Ethylene Propylene	O-ring	-40 to 200°F -40 to 93°C	100 to 750 psi 6.9 to 52 bar	Material has very good abrasion resistance. Excellent chemical resistance to phosphate esters, good to excellent to mild acids, alkalis, silicone oils and greases, ketones and alcohols. Not recommended for petroleum oils or di-esters.

Selecting the proper seal material for your application is important. We suggest using the harder plastic seals (TG) whenever possible because they provide excellent wear life. The elastomers (V, BR, K or EPR) offer enhanced sealing at low pressure because they are soft and more compliant than the plastics. However, the elastomers do not provide the same toughness or wear resistance.

PART NUMBERING SYSTEM

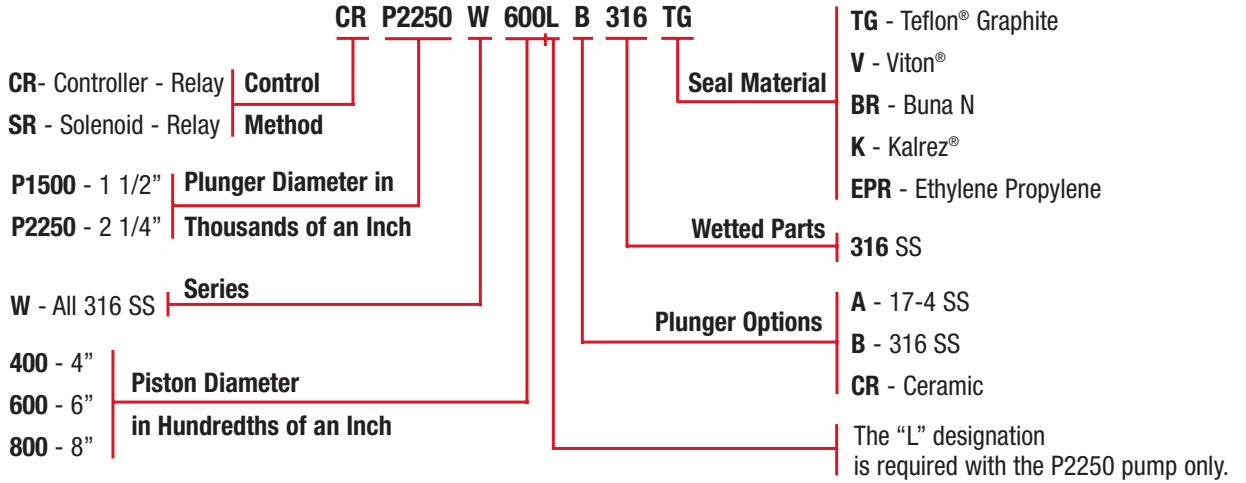

TYPICAL INSTALLATION

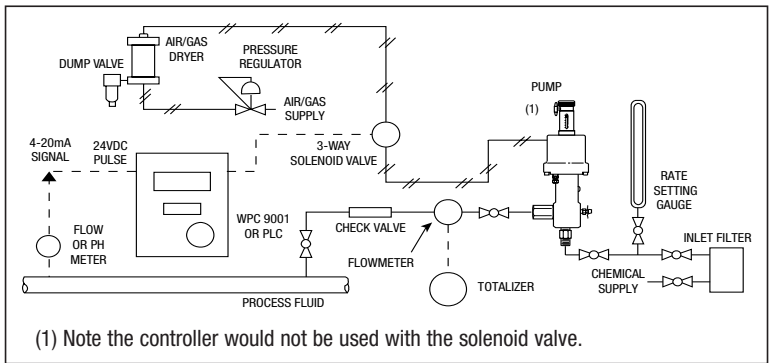

FlowTracking Controller Configuration

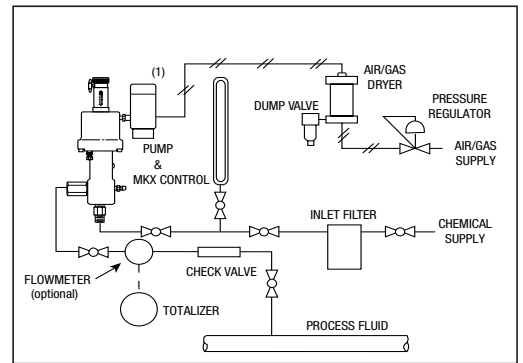

Standard Pneumatic Controller Configuration

DIMENSIONS

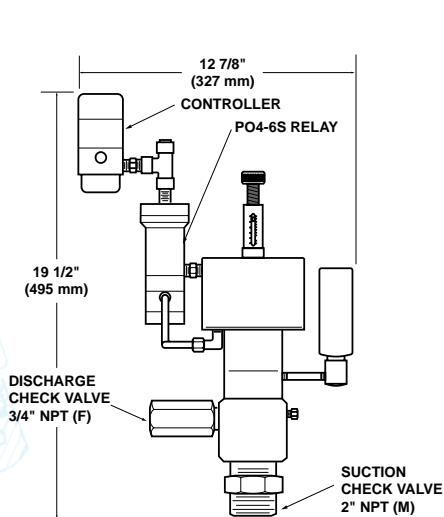

CRP1500W

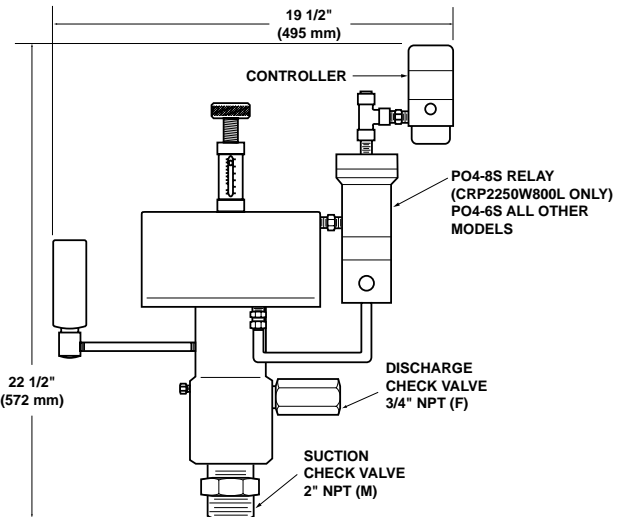

CRP2250W

PUMP ACCESSORIES



WFS6404 Micro Flow Switch For Detecting Changes in Flow Rate		
SENSITIVITY	OPERATING TEMP	OPERATING PRESSURE
0.1 PSI	-40° to +300° F	3000 PSI
0.689kPa	-40° to +150° C	207 Bar

AUTOMATIC DUMP VALVES Used with the Air or Gas Dryer-Filters		
MODELS	BOWL	MAX. PRESSURE
ADV-150-A	Plastic	150 PSI
ADV-250-A	Steel	250 PSI



DRUM GAUGES Liquid Level/Injection Rate Gauge	
MODELS	MATERIALS
C779WS	Carbon Steel
C779WS-V	Carbon Steel - Vented
C779WS/SS	Stainless Steel
C779WS/SS-V	Stainless Steel - Vented
30216-CS-V-GPD-S	Carbon Steel
30216-S6-V-GPD-S	Stainless Steel

PCV125 AL Pressure Regulator		
SENSITIVITY	FLOW RATES	MAX. PRESSURE
0.1 PSI	20SCFM	250 PSI
0.689kPa	.566m3/min	1724 kPa



LIQUID CHEMICAL FILTERS 316 Stainless Steel		
MODELS	CONNECTION FILTER ELEMENT	OPTIONAL FILTER ELEMENT
LCF10-25	1/4" NPT 25 micron, Std	1, 2, 8 microns or 100 mesh stainless steel screen
LCF15-25	1/2" NPT 25 micron, Std	

AIR OR GAS DRYER-FILTERS Complete with Manual Drain Valve		
MODELS	FLOW RATES	MAX. PRESSURE
J150	40SCFM	150 PSI
J500	40SCFM	500 PSI



APU-XP Automatic Processing Unit	
FREQUENCY	ACCURACY
0-45 SPM	± 0.25% of span

WPC9001 Electronic Pump Controller			
MODEL	NEMA CLASS	MAX. TEMP.	OPERATING MODES
WPC9001-GP	4X	140° F	Auto Manual Switching
WPC9001-XP	7	60° C	



WILLIAMS
INSTRUMENT INCORPORATED

MILTON ROY
A Sundstrand Company

NOVATEC
FLUID SYSTEMS S. A.

SOLUCIONES CONFIABLES

Sistemas y equipos para el manejo, control, dosificación y agitación de fluidos.

CALI • COLOMBIA

Calle 69 No. 7D Bis-15 - PBX: (57-2) 418 4006 - FAX: (57-2) 656 0052 / 6631997

BOGOTÁ D.C. • COLOMBIA

Cra. 14 No. 76-25 Edificio Centro Ejecutivo 76 Of. 501 - PBX: (57-1) 743 2303

www.novatecs.com
mercado@novatecs.com

PENNSYLVANIA: 201 Ivyland Road • Ivyland, PA 18974 • TEL: (800) 235-3421 • (215) 293-0415 • FAX: (215) 293-0498 • E-mail: info@williamspumps.com

CANADA: 9357 45th Avenue • Edmonton, Alberta T6E 5Z7 • TEL: (780) 434-9471 • FAX: (780) 435-6560 • E-mail: edmonton@williamspumps.com

SINGAPORE: 18 Bedok Road South • Singapore 469276 • TEL: (65) 242-9182 • FAX: (65) 243-4249 • E-mail: singapore@williamspumps.com

www.williamspumps.com